



Floodplain Use Permit- Case History

RECORD: P24FC00822

Building/Floodplain Use Permit

Case Name:NHF

Issue: Detached metal building 30x60x16.5 (no utilities) | MSR P24ZE00130

10/3/2024 Application Intake - Submitted: Created from RFCD Review ad-hoc

Case Reviewer:Stefanie Matthews

10/22/2024 Review - Note: Southern most building present in 2006 imagery, floodplain mapped in 2007. We have general covenants from 2018, may need specific covenants if floodvented.

Case Reviewer:Melissa Fisher

10/22/2024 Review - Note: Ordered archive file

Case Reviewer:Melissa Fisher

10/24/2024 Review - Supervisor RFC Review Requested: No Comments

Case Reviewer:Melissa Fisher

11/5/2024 Supervisor RFC Review - Approved with Corrections: No Comments

Case Reviewer:Francisco Ramirez

11/5/2024 Review - Request for Corrections: RFC letter emailed to applicant for MF while out of office. Letter given to Admin to mail.

Case Reviewer:Stefanie Matthews

4/15/2025 Application Intake - Note: Applicant spoke with SA for FPUP status update. Checked & appears we have not received a resubmittal. I forwarded applicant most recent email from MF & included original RFC letter from 11/05/2024. Applicant responded via email, stated, "Thank you for the update, I will reach out to our civil engineer and get some updates as I don't have anything new at the moment." See efile for correspondence.

Case Reviewer:Ben Scholl



7/18/2025 Application Intake - Resubmit: D2 received 12/20/24
Case Reviewer:Ryan Bente

7/18/2025 Review - Request for Corrections: RFC 2 (EM) sent 1/2/25
Case Reviewer:Ryan Bente

7/18/2025 Application Intake - Resubmit: D3 received 6/11/25
Case Reviewer:Ryan Bente

7/18/2025 Review - Engineering Review Requested: Engr rev requested, for PE involvement w/ Plans thus far
Case Reviewer:Ryan Bente

7/18/2025 Engineering Review - Request for Corrections: Engr RFC sent 7/14/25, stating PE needs to submit scour calcs (in place of "full" report) to justify the burial depth proposed in the plan set (2' below NG, entire perimeter).
Case Reviewer:Ryan Bente

7/18/2025 Engineering Review - Note: Clarified 7/14/25 Engr RFC with a 7/17/25 EM that included additional text-explanation, as well as an "example" scour calc sheet that could be sealed, submitted, and approved by RFCD. Both RFC/s in eFile
Case Reviewer:Ryan Bente

7/30/2025 Engineering Review - Resubmittal: Resub 7/30/25 - Engr report (Scour calcs + Mannings equation for velocity) received, reviewed, and approved, by RFCD on 7/30/25. Moving permit to Hydro (SM, thanks!) for Admin review + Issuance
Case Reviewer:Ryan Bente

7/30/2025 Engineering Review - Approved: Engr is approved. Scour calcs / details provide adequate foundation erosion protection. Passing to Hydro to issue
Case Reviewer:Ryan Bente

8/5/2025 Review - Supervisor Approval Review Requested: Completed FPUP submitted for approval.
Case Reviewer:Stefanie Matthews

8/5/2025 Supervisor Approval Review - Approved: permit approved D1FC1 uploaded to DSD
Case Reviewer:Philip Calabrese



8/5/2025 Issuance - Note: FPUP, covs, as built, and el cert emailed to applicant.

Case Reviewer:Stefanie Matthews

8/5/2025 Issuance - Issued - Documents Required: Signed FPUP received by email. Awaiting covs, P2S as built, and P2F el cert.

Case Reviewer:Stefanie Matthews

11/20/2025 Documents - Note: As-Built received, reviewed, and approved by RB on 11/20/25

Case Reviewer:Ryan Bente

12/22/2025 Documents - Documents Received: Covs were dropped off at the counter. Covs with Admin.

Case Reviewer:Saadia Sajjad

3/17/2026 Documents - Note: P2F el-cert received with corrections required. Emailed Troy John (tj@southwestbuildings.com) and engineer who completed survey Oscar Cervantes (ocervantes@xclengineering.com) for corrections.

Case Reviewer:Irene Castillo

3/23/2026 Documents - Documents Approved: P2F-El-cert reviewed and approved. Structure is flood vented. IC 3/23/3036

Case Reviewer:Irene Castillo

3/23/2026 Close Out - Complete: No Comments

Case Reviewer:Deanna Reyes

FPUP # P24FC00822

DSD # P24BP08729

ELEVATION CERTIFICATE

IMPORTANT: MUST FOLLOW THE INSTRUCTIONS ON PAGES 1-11

Copy all pages of this Elevation Certificate and all attachments for (1) community official, (2) insurance agent/company, and (3) building owner.

SECTION A – PROPERTY INFORMATION	FOR INSURANCE COMPANY USE
A1. Building Owner's Name: <u>Patrick Lorenz & Melissa May</u>	Policy Number: _____
A2. Building Street Address (including Apt., Unit, Suite, and/or Bldg. No.) or P.O. Route and Box No.: <u>3941 W Flying Diamond Dr</u>	Company NAIC Number: _____
City: <u>Tucson</u> State: <u>Arizona</u> ZIP Code: <u>85742</u>	
A3. Property Description (e.g., Lot and Block Numbers or Legal Description) and/or Tax Parcel Number: Taxcode: <u>224170240</u> Township <u>12S</u> Range <u>13E</u> Section <u>07</u>	
A4. Building Use (e.g., Residential, Non-Residential, Addition, Accessory, etc.): <u>Accessory: Detached Garage</u>	
A5. Latitude/Longitude: Lat. <u>32.398190</u> Long. <u>-111.049980</u> Horizontal Datum: <input type="checkbox"/> NAD 1927 <input checked="" type="checkbox"/> NAD 1983 <input type="checkbox"/> WGS 84	
A6. Attach at least two and when possible four clear photographs (one for each side) of the building (see Form pages 7 and 8). <i>Pima County Regional Flood Control District requires four (4) photographs</i>	
A7. Building Diagram Number: <u>1B</u>	
A8. For a building with a crawlspace or enclosure(s): a) Square footage of crawlspace or enclosure(s): <u>N/A</u> sq. ft. b) Is there at least one permanent flood opening on two different sides of each enclosed area? <input type="checkbox"/> Yes <input type="checkbox"/> No <input checked="" type="checkbox"/> N/A c) Enter number of permanent flood openings in the crawlspace or enclosure(s) within 1.0 foot above adjacent grade: Non-engineered flood openings: <u>N/A</u> Engineered flood openings: <u>N/A</u> d) Total net open area of non-engineered flood openings in A8.c: <u>N/A</u> sq. in. e) Total rated area of engineered flood openings in A8.c (attach documentation – see Instructions): <u>N/A</u> sq. ft. f) Sum of A8.d and A8.e rated area (if applicable – see Instructions): <u>N/A</u> sq. ft.	
A9. For a building with an attached garage: a) Square footage of attached garage: <u>1800</u> sq. ft. b) Is there at least one permanent flood opening on two different sides of the attached garage? <input checked="" type="checkbox"/> Yes <input type="checkbox"/> No <input type="checkbox"/> N/A c) Enter number of permanent flood openings in the attached garage within 1.0 foot above adjacent grade: Non-engineered flood openings: <u>N/A</u> Engineered flood openings: <u>6</u> d) Total net open area of non-engineered flood openings in A9.c: <u>N/A</u> sq. in. e) Total rated area of engineered flood openings in A9.c (attach documentation – see Instructions): <u>1830</u> sq. ft. f) Sum of A9.d and A9.e rated area (if applicable – see Instructions): <u>N/A</u> sq. ft.	
SECTION B – FLOOD INSURANCE RATE MAP (FIRM) INFORMATION	
B1.a. NFIP Community Name: <u>Pima County</u> B1.b. NFIP Community Identification Number: <u>040073</u>	
B2. County Name: <u>Pima County</u> B3. State: <u>Arizona</u> B4. Map/Panel No.: <u>04019C 1070</u> B5. Suffix: <u>L</u>	
B6. FIRM Index Date: <u>09/28/2012</u> B7. FIRM Panel Effective/Revised Date: <u>6/16/2011</u>	
B8. Flood Zone(s): <u>X</u> B9. Base Flood Elevation(s) (BFE) (Zone AO, use Base Flood Depth): <u>100.5</u>	
B10. Indicate the source of the BFE data or Base Flood Depth entered in Item B9: <input type="checkbox"/> FIS <input type="checkbox"/> FIRM <input checked="" type="checkbox"/> Community Determined <input type="checkbox"/> Other: _____	
B11. Indicate elevation datum used for BFE in Item B9: <input type="checkbox"/> NGVD 1929 <input type="checkbox"/> NAVD 1988 <input checked="" type="checkbox"/> Other/Source: <u>Highest Adjacent Natural Grade (=100.0 ft)</u>	
B12. Is the building located in a Coastal Barrier Resources System (CBRS) area or Otherwise Protected Area (OPA)? <input type="checkbox"/> Yes <input checked="" type="checkbox"/> No Designation Date: <u>N/A</u> <input type="checkbox"/> CBRS <input type="checkbox"/> OPA	
B13. Is the building located seaward of the Limit of Moderate Wave Action (LiMWA)? <input type="checkbox"/> Yes <input checked="" type="checkbox"/> No	

ELEVATION CERTIFICATE

IMPORTANT: MUST FOLLOW THE INSTRUCTIONS ON PAGES 1-11

Building Street Address (including Apt., Unit, Suite, and/or Bldg. No.) or P.O. Route and Box No.:

3941 W Flying Diamond Dr

City: Tucson

State: Arizona

ZIP Code: 85742

FOR INSURANCE COMPANY USE

Policy Number: _____

Company NAIC Number: _____

SECTION C – BUILDING ELEVATION INFORMATION (SURVEY REQUIRED)

C1. Building elevations are based on: Construction Drawings* Building Under Construction* Finished Construction

*A new Elevation Certificate will be required when construction of the building is complete.

C2. Elevations – Zones A1–A30, AE, AH, AO, A (with BFE), VE, V1–V30, V (with BFE), AR, AR/A, AR/AE, AR/A1–A30, AR/AH, AR/AO, A99. Complete Items C2.a–h below according to the Building Diagram specified in Item A7. In Puerto Rico only, enter meters.

Benchmark Utilized: Pinal Co Sta ID: 12S13E_G05 Vertical Datum: NAVD88 Elev 2528.48

PCRFCD Note: When HANG is used as Datum, fill out "Vertical Datum" as "LOCAL"

Indicate elevation datum used for the elevations in items a) through h) below.

NGVD 1929 NAVD 1988 Other: _____

Datum used for building elevations must be the same as that used for the BFE. Conversion factor used?

Yes No

If Yes, describe the source of the conversion factor in the Section D Comments area.

Check the measurement used:

a) Top of bottom floor (including basement, crawlspace, or enclosure floor):

2527.71

feet meters

b) Top of the next higher floor (see Instructions):

N/A

feet meters

c) Bottom of the lowest horizontal structural member (see Instructions):

N/A

feet meters

d) Attached garage (top of slab):

2527.71

feet meters

e) Lowest elevation of Machinery and Equipment (M&E) servicing the building (describe type of M&E and location in Section D Comments area):

N/A

feet meters

f) Lowest Adjacent Grade (LAG) next to building: Natural Finished

2525.85

feet meters

PCRFCD Note : Indicate lowest adjacent natural grade (LANG) in Section D.

g) Highest Adjacent Grade (HAG) next to building: Natural Finished

2527.20

feet meters

PCRFCD Note : Indicate highest adjacent natural grade (HANG) in Section D.

h) Finished LAG at lowest elevation of attached deck or stairs, including structural support:

N/A

feet meters

SECTION D – SURVEYOR, ENGINEER, OR ARCHITECT CERTIFICATION

This certification is to be signed and sealed by a land surveyor, engineer, or architect authorized by state law to certify elevation information. I certify that the information on this Certificate represents my best efforts to interpret the data available. I understand that any false statement may be punishable by fine or imprisonment under 18 U.S. Code, Section 1001.

Were latitude and longitude in Section A provided by a licensed land surveyor? Yes No

Check here if attachments and describe in the Comments area.

Certifier's Name: Oscar Cervantes

License Number: 48178

Title: Civil Engineer

Company Name: XCL Engineering LLC

Address: 1460 S Karen Dr

City: Chandler

State: AZ

ZIP Code: 85286

Signature: Oscar Omar Cervantes

Date: 3/13/26

Telephone: (602) 790-2267

Ext.: _____

Email: ocervantes@xclengineering.com

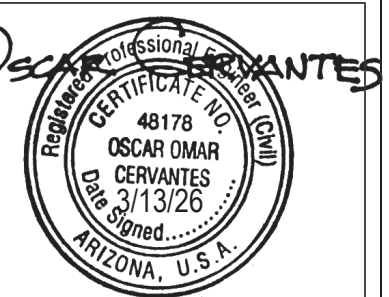

Place Seal Here

Copy all pages of this Elevation Certificate and all attachments for (1) community official, (2) insurance agent/company, and (3) building owner.

Comments (including source of conversion factor in C2; type of equipment and location per C2.e; and description of any attachments):

Highest adjacent natural grade is 2527.20 Lowest adjacent natural grade is 2525.85

Flood Vent Model # CSBA816

ELEVATION CERTIFICATE

IMPORTANT: MUST FOLLOW THE INSTRUCTIONS ON PAGES 1-11

Building Street Address (including Apt., Unit, Suite, and/or Bldg. No.) or P.O. Route and Box No.:

3941 W Flying Diamond Dr

City: Tucson

State: Arizona

ZIP Code: 85742

FOR INSURANCE COMPANY USE

Policy Number: _____

Company NAIC Number: _____

SECTION E – BUILDING MEASUREMENT INFORMATION (SURVEY NOT REQUIRED) FOR ZONE AO, ZONE AR/AO, AND ZONE A (WITHOUT BFE)

For Zones AO, AR/AO, and A (without BFE), complete Items E1–E5. For Items E1–E4, use natural grade, if available. If the Certificate is intended to support a Letter of Map Change request, complete Sections A, B, and C. Check the measurement used. In Puerto Rico only, enter meters.

Building measurements are based on: Construction Drawings* Building Under Construction* Finished Construction

*A new Elevation Certificate will be required when construction of the building is complete.

E1. Provide measurements (C.2.a in applicable Building Diagram) for the following and check the appropriate boxes to show whether the measurement is above or below the natural HAG and the LAG.

a) Top of bottom floor (including basement, crawlspace, or enclosure) is: _____ feet meters above or below the HAG.

b) Top of bottom floor (including basement, crawlspace, or enclosure) is: _____ feet meters above or below the LAG.

E2. For Building Diagrams 6–9 with permanent flood openings provided in Section A Items 8 and/or 9 (see pages 1–2 of Instructions), the next higher floor (C2.b in applicable Building Diagram) of the building is: _____ feet meters above or below the HAG.

E3. Attached garage (top of slab) is: _____ feet meters above or below the HAG.

E4. Top of platform of machinery and/or equipment servicing the building is: _____ feet meters above or below the HAG.

E5. Zone AO only: If no flood depth number is available, is the top of the bottom floor elevated in accordance with the community's floodplain management ordinance? Yes No Unknown The local official must certify this information in Section G.

SECTION F – PROPERTY OWNER (OR OWNER'S AUTHORIZED REPRESENTATIVE) CERTIFICATION

The property owner or owner's authorized representative who completes Sections A, B, and E for Zone A (without BFE) or Zone AO must sign here. *The statements in Sections A, B, and E are correct to the best of my knowledge*

Check here if attachments and describe in the Comments area.

Property Owner or Owner's Authorized Representative Name: _____

Address: _____

City: _____ State: _____ ZIP Code: _____

Signature: _____ Date: _____

Telephone: _____ Ext.: _____ Email: _____

Comments: _____

ELEVATION CERTIFICATE

IMPORTANT: MUST FOLLOW THE INSTRUCTIONS ON PAGES 1-11

Building Street Address (including Apt., Unit, Suite, and/or Bldg. No.) or P.O. Route and Box No.:

3941 W Flying Diamond Dr

City: Tucson

State: Arizona

ZIP Code: 85742

FOR INSURANCE COMPANY USE

Policy Number: _____

Company NAIC Number: _____

SECTION G – COMMUNITY INFORMATION (RECOMMENDED FOR COMMUNITY OFFICIAL COMPLETION)

The local official who is authorized by law or ordinance to administer the community's floodplain management ordinance can complete Section A, B, C, E, G, or H of this Elevation Certificate. Complete the applicable item(s) and sign below when:

- G1. The information in Section C was taken from other documentation that has been signed and sealed by a licensed surveyor, engineer, or architect who is authorized by state law to certify elevation information. (Indicate the source and date of the elevation data in the Comments area below.)
- G2.a. A local official completed Section E for a building located in Zone A (without a BFE), Zone AO, or Zone AR/AO, or when item E5 is completed for a building located in Zone AO.
- G2.b. A local official completed Section H for insurance purposes.
- G3. In the Comments area of Section G, the local official describes specific corrections to the information in Sections A, B, E and H.
- G4. The following information (Items G5–G11) is provided for community floodplain management purposes.
- G5. Permit Number: P24FC00822 G6. Date Permit Issued: _____
- G7. Date Certificate of Compliance/Occupancy Issued: _____
- G8. This permit has been issued for: New Construction Substantial Improvement
- G9.a. Elevation of as-built lowest floor (including basement) of the building: _____ feet meters Datum: _____
- G9.b. Elevation of bottom of as-built lowest horizontal structural member: _____ feet meters Datum: _____
- G10.a. BFE (or depth in Zone AO) of flooding at the building site: 100.5 feet meters Datum: HANG
- G10.b. Community's minimum elevation (or depth in Zone AO) requirement for the lowest floor or lowest horizontal structural member: 101.5 feet meters Datum: HANG
- G11. Variance issued? Yes No If yes, attach documentation and describe in the Comments area.

The local official who provides information in Section G must sign here. *I have completed the information in Section G and certify that it is correct to the best of my knowledge. If applicable, I have also provided specific corrections in the Comments area of this section.*

Local Official's Name: Stefanie Matthews

Title: Hydrologist

NFIP Community Name: Pima County

Telephone: 520-724-4600

Ext.: _____

Email: _____

Address: 201 N Stone Ave 9th Fl

City: Tucson

State: AZ

ZIP Code: 85701

Signature: Stefanie Matthews

Date: 8/05/2025

Comments (including type of equipment and location, per C2.e; description of any attachments; and corrections to specific information in Sections A, B, D, E, or H):

ELEVATION CERTIFICATE

IMPORTANT: MUST FOLLOW THE INSTRUCTIONS ON PAGES 1-11

Building Street Address (including Apt., Unit, Suite, and/or Bldg. No.) or P.O. Route and Box No.:

3941 W Flying Diamond Dr

City: Tucson

State: Arizona

ZIP Code: 85742

FOR INSURANCE COMPANY USE

Policy Number: _____

Company NAIC Number: _____

SECTION H – BUILDING'S FIRST FLOOR HEIGHT INFORMATION FOR ALL ZONES (SURVEY NOT REQUIRED) (FOR INSURANCE PURPOSES ONLY)

The property owner, owner's authorized representative, or local floodplain management official may complete Section H for all flood zones to determine the building's first floor height for insurance purposes. Sections A, B, and I must also be completed. Enter heights to the nearest tenth of a foot (nearest tenth of a meter in Puerto Rico). **Reference the Foundation Type Diagrams (at the end of Section H Instructions) and the appropriate Building Diagrams (at the end of Section I Instructions) to complete this section.**

H1. Provide the height of the top of the floor (as indicated in Foundation Type Diagrams) above the Lowest Adjacent Grade (LAG):

a) **For Building Diagrams 1A, 1B, 3, and 5–8.** Top of bottom _____ feet meters above the LAG floor (include above-grade floors only for buildings with subgrade crawlspaces or enclosure floors) is:

b) **For Building Diagrams 2A, 2B, 4, and 6–9.** Top of next higher floor (i.e., the floor above basement, crawlspace, or enclosure floor) is: _____ feet meters above the LAG

H2. Is **all** Machinery and Equipment servicing the building (as listed in Item H2 instructions) elevated to or above the floor indicated by the H2 arrow (shown in the Foundation Type Diagrams at end of Section H instructions) for the appropriate Building Diagram?

Yes No

SECTION I – PROPERTY OWNER (OR OWNER'S AUTHORIZED REPRESENTATIVE) CERTIFICATION

The property owner or owner's authorized representative who completes Sections A, B, and H must sign here. *The statements in Sections A, B, and H are correct to the best of my knowledge.* **Note:** If the local floodplain management official completed Section H, they should indicate in Item G2.b and sign Section G.

Check here if attachments are provided (including required photos) and describe each attachment in the Comments area.

Property Owner or Owner's Authorized Representative Name: _____

Address: _____

City: _____ State: _____ ZIP Code: _____

Signature: _____ Date: _____

Telephone: _____ Ext.: _____ Email: _____

Comments: _____

ELEVATION CERTIFICATE
IMPORTANT: MUST FOLLOW THE INSTRUCTIONS ON PAGES 1-11
BUILDING PHOTOGRAPHS

See Instructions for Item A6.

Building Street Address (including Apt., Unit, Suite, and/or Bldg. No.) or P.O. Route and Box No.:
3941 W Flying Diamond Dr

City: Tucson State: Arizona ZIP Code: 85742

FOR INSURANCE COMPANY USE

Policy Number: _____

Company NAIC Number: _____

Instructions: Insert below at least two and when possible four photographs showing each side of the building (for example, may only be able to take front and back pictures of townhouses/rowhouses). Identify all photographs with the date taken and "Front View," "Rear View," "Right Side View," or "Left Side View." Photographs must show the foundation. When flood openings are present, include at least one close-up photograph of representative flood openings or vents, as indicated in Sections A8 and A9.



Photo One

Photo One Caption: South side of Building 3/19/26



Photo Two

Photo Two Caption: East side of Building 3/19/26

ELEVATION CERTIFICATE
IMPORTANT: MUST FOLLOW THE INSTRUCTIONS ON PAGES 1-11
BUILDING PHOTOGRAPHS

Continuation Page

Building Street Address (including Apt., Unit, Suite, and/or Bldg. No.) or P.O. Route and Box No.:

3941 W Flying Diamond Dr

City: Tucson

State: Arizona

ZIP Code: 85742

FOR INSURANCE COMPANY USE

Policy Number: _____

Company NAIC Number: _____

Insert the third and fourth photographs below. Identify all photographs with the date taken and "Front View," "Rear View," "Right Side View," or "Left Side View." When flood openings are present, include at least one close-up photograph of representative flood openings or vents, as indicated in Sections A8 and A9.



Photo Three

Photo Three Caption: East side of Building 3/19/26



Photo Four

Photo Four Caption: North side of Building 3/19/26

ICC-ES Evaluation Report

ESR-3851

Reissued September 2024

This report also contains:

- CBC Supplement

- FBC Supplement

Subject to renewal September 2025

ICC-ES Evaluation Reports are not to be construed as representing aesthetics or any other attributes not specifically addressed, nor are they to be construed as an endorsement of the subject of the report or a recommendation for its use. There is no warranty by ICC Evaluation Service, LLC, express or implied, as to any finding or other matter in this report, or as to any product covered by the report.

Copyright © 2024 ICC Evaluation Service, LLC. All rights reserved.

<p>DIVISION: 08 00 00 - OPENINGS</p> <p>Section: 08 95 43— Vents/Foundation Flood Vents</p>	<p>REPORT HOLDER:</p> <p>CRAWL SPACE DOOR SYSTEMS, INC.</p>	<p>EVALUATION SUBJECT:</p> <p>CRAWL SPACE DOOR SYSTEMS FLOOD VENT MODEL #CSBA816</p> <p>CRAWL SPACE STACKED MODELS:</p> <p>#ICCSTACKED2;</p> <p>#ICCSTACKED4</p> <p>FLOOD VENT INSULATED KIT</p> <p>#ICCINSULATED</p>	
---	---	--	---

1.0 EVALUATION SCOPE

Compliance with the following codes:

- 2021, 2018 and 2015 [International Building Code® \(IBC\)](#)
- 2021, 2018 and 2015 [International Residential Code® \(IRC\)](#)

Properties evaluated:

- Physical operation
- Water flow
- Weathering

2.0 USES

Crawl Space Door Systems flood vents are used to provide for the equalization of hydrostatic flood forces on exterior walls.

3.0 DESCRIPTIONS

3.1 General:

Crawl Space Door Systems flood vents are engineered mechanically operated flood vents. Upon contact with flood water, the flood vents automatically open and allow flood water to enter and exit enclosed areas. The vents are constructed of general purpose ABS SP-9010 plastic. The Crawl Space Flood Vent Model #CSBA816 has a faux louver with either a solid plastic plate or wire mesh attached to the back of the louver. The louver is dislodged from the vent upon contact with flood waters. See [Figure 1](#) for an illustration of the flood vent Model #CSBA816.

The Flood Vent Insulated Kit Model #ICCINSULATED is constructed of general purpose ABS SP-9010 plastic. The vent frame opening is filled with a 2-inch thick (51 mm) extruded polystyrene Styrofoam™ Brand Scoreboard Foam Insulation Board (ESR-2142). The insulation board is dislodged from the vent upon contact with flood waters, allowing flood waters to enter and exit enclosed areas. See [Figure 2](#) for an illustration of the Flood Vent Insulated Kit Model #ICCINSULATED.

The Crawl Space Stacked Model #ICCSTACKED2 contains two vertically arranged Crawl Space Flood Vents (Model #CSBA816) in one assembly. The Crawl Space Stacked Model #ICCSTACKED4 contains four Crawl Space Flood Vents (Model #CSBA816) in one assembly, with two sets of side by side flood vents vertically arranged.

3.2 Engineered Opening:

The Crawl Space Door Systems static flood vents comply with the design principle noted in Section 2.7.2.2 of ASCE/SEI 24 for a rate of rise and fall of 5 feet per hour (0.423 mm/s). In order to comply with the engineered opening requirement of ASCE/SEI 24-14, the flood vents must be installed in accordance with Section 4.0 of this report.

3.3 Ventilation:

The Crawl Space Flood Vent Model #CSBA816 and Crawl Space Stacked Models #ICCSTACKED2 and #ICCSTACKED4 are available covered with metal wire mesh with 0.108 inch by 0.108 inch (2.74 mm by 2.74 mm) openings. The mesh is covered by a faux louver with $1\frac{1}{16}$ inch (17.5 mm) vertical clearance between each blade. The Crawl Space Flood Vent Model #CSBA816 provides 11 square inches (7097 mm²) of net free area to supply natural ventilation when equipped with wire mesh. The Crawl Space Stacked Models #ICCSTACKED2 and #ICCSTACKED4 supply 22 square inches (14,194 mm²) and 44 square inches (28,388 mm²), respectively, of net free area to supply natural ventilation when equipped with wire mesh. The Crawl Space Flood Vent Model #CSBA816 covered with a solid plastic plate, Crawl Space Stacked Models #ICCSTACKED2 and #ICCSTACKED4 covered with a solid plastic plate, and the Flood Vent Insulated Kit Model #ICCINSULATED do not offer natural ventilation.

4.0 DESIGN AND INSTALLATION

The Crawl Space Door Systems flood vents are designed to be installed into walls or doors of existing or new construction from the exterior side. Installation of the vents must be in accordance with the manufacturer's instructions, the applicable code and this report. In order to comply with the engineered opening design principle noted in Sections 2.7.2.2 and 2.7.3 of ASCE/SEI 24-14, the vent must be installed as follows:

- With a minimum of two openings; one on different sides of each enclosed area.
- With a minimum of one vent for the square footage of enclosed area noted in [Table 1](#).
- Below the base flood elevation.
- With the bottom of the vent located a maximum of 12 inches (305 mm) above grade.

5.0 CONDITIONS OF USE

The Crawl Space Door Systems flood vents described in this report comply with, or are suitable alternatives to what is specified in, those codes listed in Section 1.0 of this report, subject to the following conditions:

- 5.1 The Crawl Space Door Systems flood vents must be installed in accordance with this report, the applicable code and the manufacturer's published installation instructions. In the event of a conflict, the instructions in this report govern.
- 5.2 The Crawl Space Door Systems flood vents must not be used in the place of "breakaway walls" in coastal high hazard areas but are permitted for use in conjunction with breakaway walls in other areas.
- 5.3 The Crawl Space Door Systems flood vents are manufactured under a quality control system with inspections by ICC-ES.

6.0 EVIDENCE SUBMITTED

Data in accordance with the [ICC-ES Acceptance Criteria for Mechanically Operated Flood Vents \(AC364\)](#), dated August 2015 (Editorially revised April 2021).

7.0 IDENTIFICATION

- 7.1 The ICC-ES mark of conformity, electronic labeling, or the evaluation report number (ICC-ES ESR-3851) along with the name, registered trademark, or registered logo of the report holder must be included in the product label.
- 7.2 In addition, The Crawl Space Door Systems flood vents recognized in this report must be identified by a label bearing the manufacturer's name (Crawl Space Door Systems) and the model number.

7.3 The report holder’s contact information is the following:

CRAWL SPACE DOOR SYSTEMS, INC.
3669 SEA GULL BLUFF DRIVE
VIRGINIA BEACH, VIRGINIA 23455
(757) 363-0005
www.crawlspacedoors.com

TABLE 1—CRAWL SPACE DOOR SYSTEMS FLOOD VENTS

MODEL	OVERALL VENT SIZE (Width x Height x Depth) (in)	ROUGH OPENING SIZE (Width x Height) (in)	ENCLOSED AREA COVERAGE ¹ (ft ²)
CSBA816	18 ¹ / ₄ x 10 ¹ / ₂ x 1 ³ / ₄	16 x 8 ¹ / ₄	ocerv Highlight
ICCINSULATED	18 ¹ / ₄ x 10 ¹ / ₂ x 1 ³ / ₄	15 ³ / ₄ x 8	
ICCSTACKED2	30 x 30 x 2 ³ / ₄	24 x 24	
ICCSTACKED4	40 ¹ / ₂ x 24 ³ / ₄ x 2 ³ / ₄	35 ¹ / ₄ x 19 ¹ / ₂	

For **SI**: 1 inch = 25.4 mm; 1ft² = 0.093 m²

¹The enclosed coverage area in square feet for each model is equivalent to the performance of the same number of square inches of non-engineered openings.

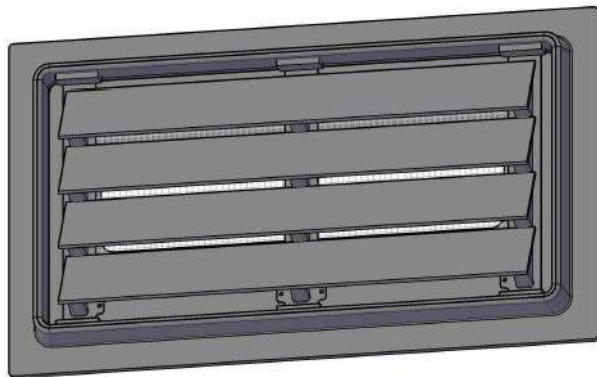

FIGURE 1—CRAWL SPACE DOOR SYSTEMS FLOOD VENT

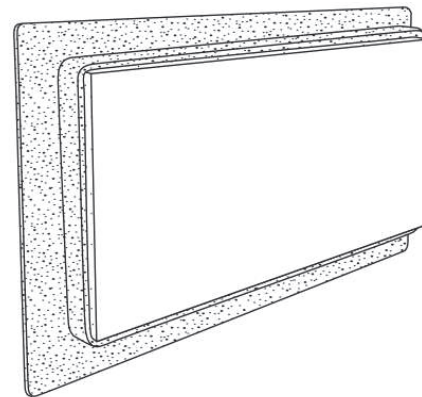

FIGURE 2—FLOOD VENT INSULATED KIT

DIVISION: 08 00 00—OPENINGS
Section: 08 95 43—Vents/Foundation Flood Vents

REPORT HOLDER:

CRAWL SPACE DOOR SYSTEMS, INC.

EVALUATION SUBJECT:

CRAWL SPACE DOOR SYSTEMS FLOOD VENT MODEL #CSBA816
CRAWL SPACE STACKED MODELS #ICCSTACKED2; #ICCSTACKED4
FLOOD VENT INSULATED KIT #ICCINSULATED

1.0 REPORT PURPOSE AND SCOPE**Purpose:**

The purpose of this evaluation report supplement is to indicate that Crawl Space Door Systems flood vents, described in ICC-ES evaluation report [ESR-3851](#), have also been evaluated for compliance with the code(s) noted below.

Applicable code editions:

- 2022 California Building Code (CBC)

For evaluation of applicable chapters adopted by the California Office of Statewide Health Planning and Development (OSHPD) AKA: California Department of Health Care Access and Information (HCAI) and the Division of State Architect (DSA), see Sections 2.1.1 and 2.1.2 below.

- 2022 California Residential Code (CRC)

2.0 CONCLUSIONS**2.1 CBC:**

The Crawl Space Door Systems flood vents, described in Sections 2.0 through 7.0 of the evaluation report [ESR-3851](#), comply with CBC Chapter 12, provided the design and installation are in accordance with the 2021 *International Building Code*® (IBC) provisions noted in the evaluation report and the additional requirements of CBC Chapters 12 and 16, as applicable.

2.1.1 OSHPD:

The applicable OSHPD Sections and Chapters of the CBC are beyond the scope of this supplement.

2.1.2 DSA:

The applicable DSA Sections and Chapters of the CBC are beyond the scope of this supplement.

2.2 CRC:

The Crawl Space Door Systems flood vents, described in Sections 2.0 through 7.0 of the evaluation report [ESR-3851](#), comply with 2022 CRC, provided the design and installation are in accordance with the 2021 *International Residential Code*® (IRC) provisions noted in the evaluation report.

This supplement expires concurrently with the evaluation report, reissued September 2024.

DIVISION: 08 00 00—OPENINGS

Section: 08 95 43—Vents/Foundation Flood Vents

REPORT HOLDER:

CRAWL SPACE DOOR SYSTEMS, INC.

EVALUATION SUBJECT:

CRAWL SPACE DOOR SYSTEMS FLOOD VENT MODEL #CSBA816
CRAWL SPACE STACKED MODELS #ICCSTACKED2; #ICCSTACKED4
FLOOD VENT INSULATED KIT #ICCINSULATED

1.0 REPORT PURPOSE AND SCOPE

Purpose:

The purpose of this evaluation report supplement is to indicate that Crawl Space Door Systems flood vents, described in ICC-ES evaluation report ESR-3851, have also been evaluated for compliance with the codes noted below.

Applicable code editions:

- 2023 Florida Building Code—Building
- 2023 Florida Building Code—Residential

2.0 CONCLUSIONS

The Crawl Space Door Systems flood vents, described in Sections 2.0 through 7.0 of ICC-ES evaluation report ESR-3851, comply with the *Florida Building Code—Building* and *Florida Building Code—Residential*. The design requirements must be determined in accordance with the *Florida Building Code—Building* and *Florida Building Code—Residential*, as applicable. The installation requirements noted in ICC-ES evaluation report ESR-3851 for the 2021 *International Building Code*® meet the requirements of the *Florida Building Code—Building* and *Florida Building Code—Residential*, as applicable.

Use of the Crawl Space Door Systems flood vents has also been found to be in compliance with the High-Velocity Hurricane Zone provisions of the 2023 *Florida Building Code—Building* and *Florida Building Code—Residential*.

For products falling under Florida Rule 61G20-3, verification that the report holder's quality assurance program is audited by a quality assurance entity approved by the Florida Building Commission for the type of inspections being conducted is the responsibility of an approved validation entity (or the code official when the report holder does not possess an approval by the Commission).

This supplement expires concurrently with the evaluation report, reissued September 2024.